

# TECHNICAL REVIEW

OrthoShear Accelerometer Design  
QC Test for Knock Sensors  
Torsional Operational Deflection Shapes

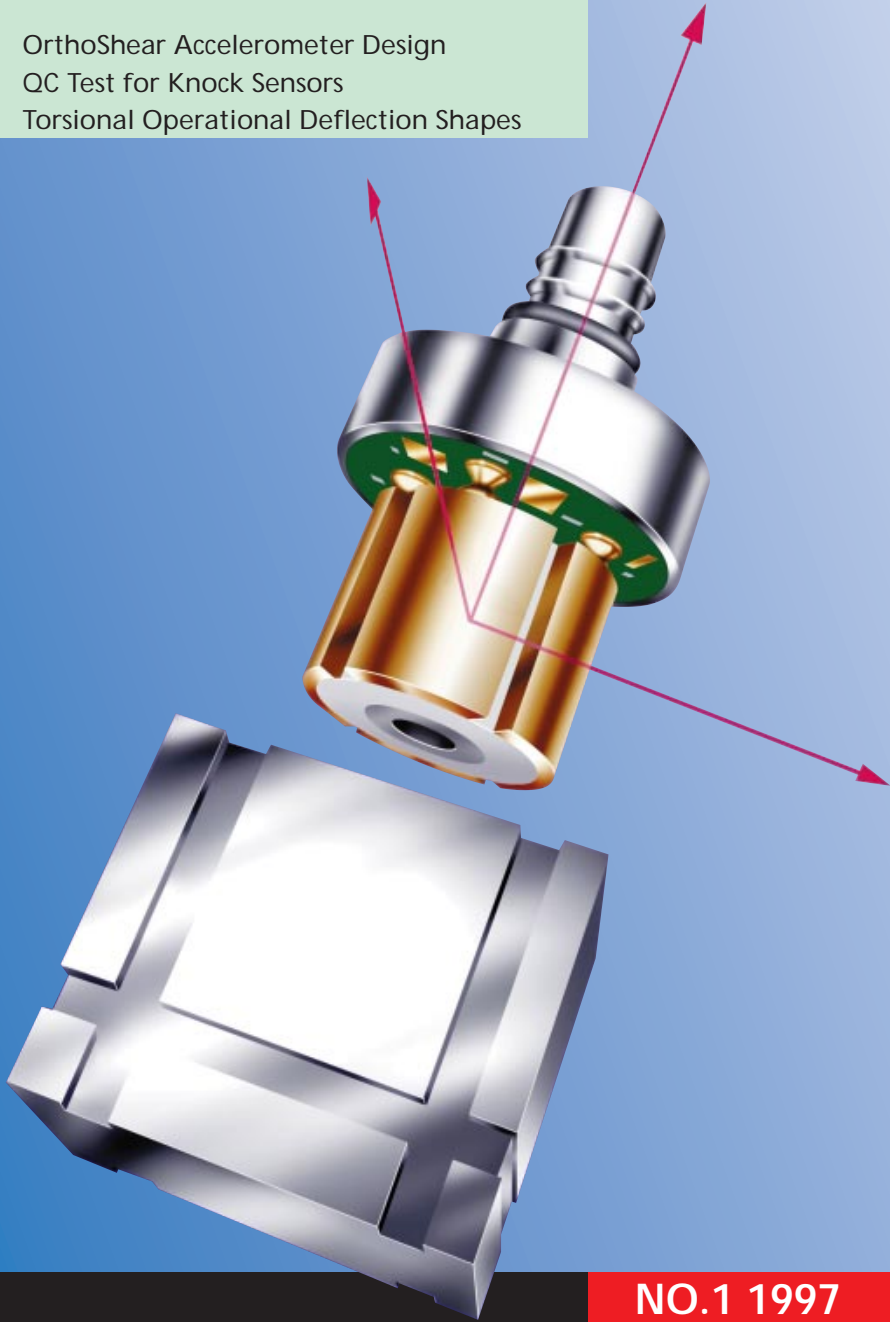

NO.1 1997

Brüel & Kjær 

# Technical Review

No. 1 – 1997

# Contents

<b>A New Design Principle for Triaxial Piezoelectric Accelerometers .....</b>	<b>1</b>
<i>by Knud Styhr Hansen</i>	
<b>A Simple QC Test for Knock Sensors .....</b>	<b>12</b>
<i>S. Gade, S. Møllebjerg Matzen, H. Herlufsen,</i>	
<b>Torsional Operational Deflection Shapes (TODS) Measurements .....</b>	<b>24</b>
<i>Svend Gade, Kevin Gatzwiller, Henrik Herlufsen</i>	

Copyright © 1997, Brüel & Kjær Sound & Vibration Measurement A/S  
All rights reserved. No part of this publication may be reproduced or distributed in any form, or  
by any means, without prior written permission of the publishers. For details, contact:  
Brüel & Kjær Sound & Vibration Measurement A/S, DK-2850 Nærum, Denmark.

Editor: Harry K. Zaveri  
Layout: Judith Sarup

Photographer: Peder Dalmo  
Printed by Highlight Tryk

# A New Design Principle for Triaxial Piezoelectric Accelerometers

*by Knud Styhr Hansen*

## Abstract

The most common way of producing a triaxial piezoelectric accelerometer is to mount three single axial units with their axes perpendicular to each other in a common housing. If the units are shear accelerometers, each unit will most likely contain one piezoelectric ring or two or three piezoelectric plates and a corresponding number of seismic masses.

A new design is described in which the many piezoelectric elements and seismic masses are replaced by one piezoelectric ring and one seismic mass to form a triaxial shear accelerometer. Apart from the obvious advantage in production cost, it also gives a much more compact construction which enables lower weight for same sensitivity.

## Résumé

Cet article décrit comment le principe de construction traditionnel d'un accéléromètre triaxial (une masse sismique et un anneau piézoélectrique pour chaque axe) peut être remplacé par une conception n'utilisant qu'une masse sismique et un anneau pour les trois axes. En réglant le gain des préamplificateurs, la sensibilité des axes x, y et z peut être connue avec une incertitude de  $\pm 5\%$ . Cet article rappelle les modalités du passage d'une conception monoaxiale à une conception biaxiale, puis triaxiale. Cette construction brevetée est désignée par le nom "Orthoshear" (protégé par copyright).

## Zusammenfassung

Dieser Artikel beschreibt, wie sich die traditionelle Konstruktionsweise von Triaxialaufnehmern (eine seismische Masse und ein piezoelektrischer Ring pro Achse) durch eine neue Bauart ersetzen läßt, die mit nur einer Masse und einem piezoelektrischen Ring für sämtliche drei Achsen auskommt. Durch Justieren der Verstärkung in den drei Vorverstärkern läßt sich für alle drei Ach-

sen (x, y und z) eine Querempfindlichkeit von weniger als 5% erreichen. Der Artikel beschreibt, wie das Prinzip von der uniaxialen über die biaxiale zur triaxialen Bauart erweitert wurde. Die Bauart wurde unter dem urheberrechtlich geschützten Namen "OrthoShear" patentiert.

## Basic Principle

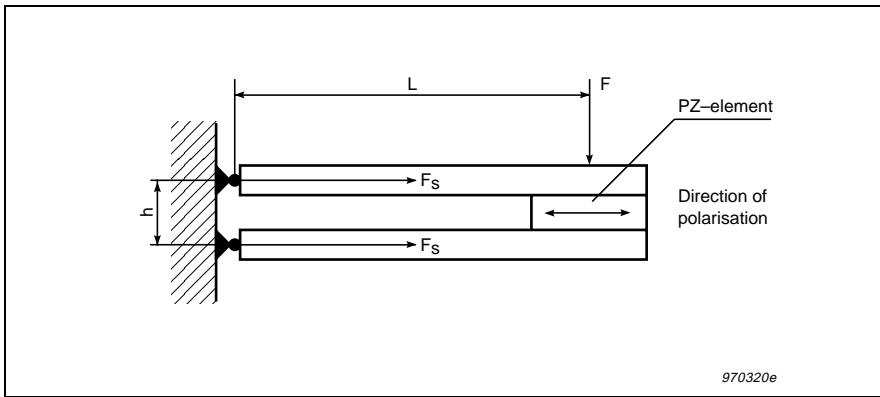

Fig. 1. Principle of the shear-beam

The design is based on a principle which implies that a force perpendicular to the surface of a plate can be transformed into a shear force in the plane of the plate. This principle is illustrated in Fig. 1 which is a schematic drawing of a single axial unit. The construction, which we call a **"shear-beam"**, consists of two stiff beams connected at one end to a stiff base by means of hinges, and at the other end to opposite surfaces of a pz-element. As the hinges cannot transfer moment, the shown force  $F$  perpendicular to the surface of the pz-element results in a force couple ( $F_s$ ,  $F_s$ ) with the arm  $h$ .

The relation is given by:

$$F \times L = F_s \times h \tag{1}$$

or:

2

$$F_s = F \times \frac{L}{h} \quad (2)$$

As can be seen, the force  $F$  perpendicular to the pz-element has been transformed to a shear force in the plane of the pz-element. At the same time it has been amplified by the factor  $L/h$ .

If the shear-beam in Fig. 1 was an accelerometer, the force  $F$  would be the inertial force from accelerating the total mass of beams and pz-element and  $L$  would be the distance from the hinges to the point of gravity of the said total mass.

The charge sensitivity of such an accelerometer would be:

$$\frac{Q}{a} = d_{15} \times M \times \frac{L}{h}; \quad \left[ \frac{C}{ms^{-2}} \right] \quad (3)$$

where  $d_{15}$  is the piezoelectric constant for shear mode excitation and  $M$  is the total mass of beams and pz-element.

The expression is valid under the assumption that the hinges are ideal. In practice this is difficult to achieve. However, it is sufficient that each arm alone is much more easily tilted than the combination of the two arms and the pz-element, and this is not difficult to achieve.

## Single Axial Application of Principle

Fig. 2 shows a proposal for a single axial accelerometer after the shear-beam principle. Here some extra mass has been added to increase the sensitivity. As can be seen, the construction is made symmetrical to avoid exciting the cross-axis resonance. At the same time it removes the roll sensitivity. As the two pz-elements are electrically connected in parallel the charge sensitivity will be twice the value mentioned above. The hinges are here realised by weakening the arms by notches close to the base. This is sufficiently close to ideal hinges.

In Fig. 3a and 3b another example of a single axial accelerometer is shown. Here a seismic mass has been placed between the "arms" and sandwiched between two pz-elements.

In Fig. 3a the accelerometer is excited in the X-direction as indicated by the horizontal arrow. In this case the construction can be looked upon as a shear-

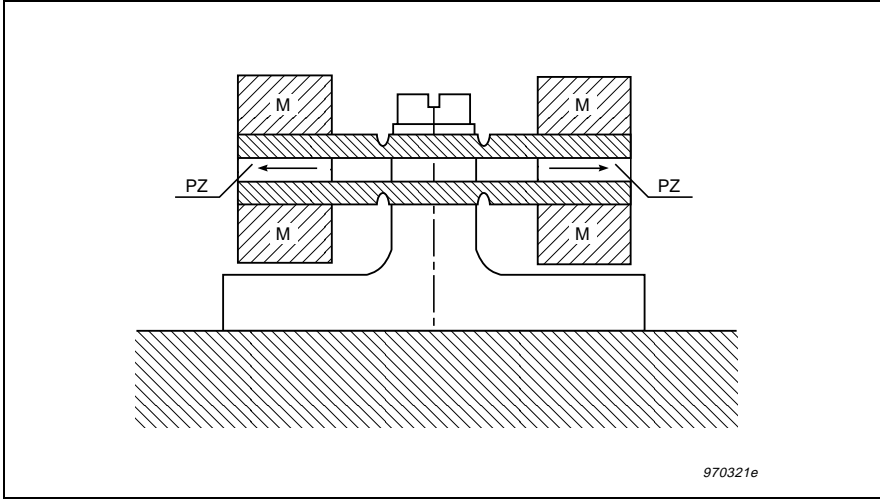

Fig. 2. Sketch of single axial shear-beam accelerometer

beam design, and the charges on the pz-elements will have a polarity as indicated by the plus and minus signs.

In Fig. 3b the accelerometer is excited in the Z-direction as indicated by the vertical arrow. In this case the construction is a well-known shear design, and the charges on the pz-elements will have a polarity as indicated by the plus and minus signs.

The charge sensitivity in the two cases will be:

$$\text{Shear-beam design: } \frac{Q_x}{a} = d_{15} \times M \times \frac{L}{h}; \left[ \frac{C}{ms^{-2}} \right] \quad (4)$$

$$\text{"Normal" shear design: } \frac{Q_z}{a} = d_{15} \times M; \left[ \frac{C}{ms^{-2}} \right] \quad (5)$$

In the case of the shear-beam design it should be noted that M is the total mass of the seismic mass, the two pz-elements, and the arms, whereas in the

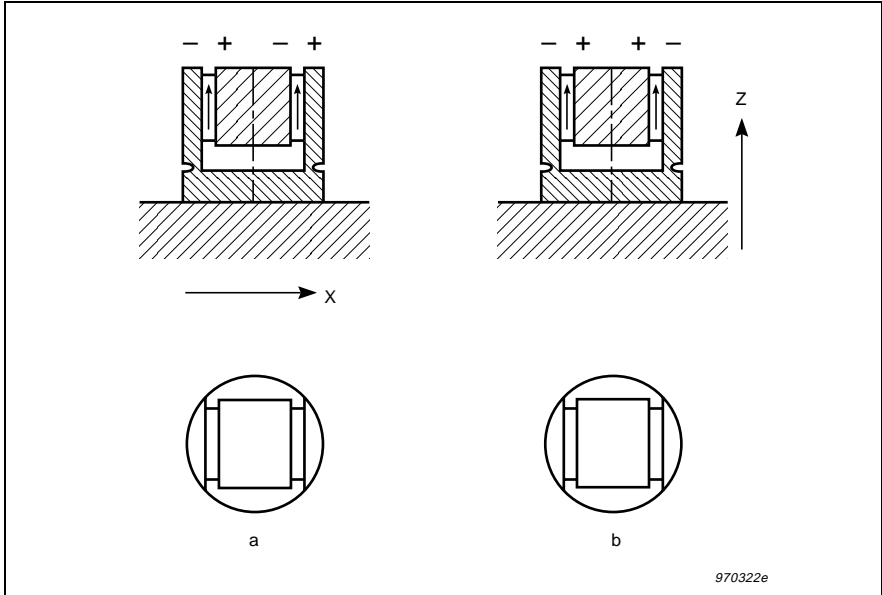

Fig. 3. Polarity of charges on pz-elements for different directions of excitation

case of the “normal” shear design  $M$  is the mass of the seismic mass and half of the pz-elements only.

## Biaxial Accelerometer

From the signs of the charges in Figs. 3a and 3b it can be seen that it must be possible to make a biaxial accelerometer by proper connection of the pz-elements to two amplifiers as shown in Fig. 4.

As seen, the right-hand side of the right-hand pz-element is connected to a charge amplifier, the output of which represents the X-channel. The central mass is connected to a voltage amplifier, the output of which represents the Z-channel. The left-hand side of the left pz-element is connected to ground.

It is worth noting that, although the central mass in both cases is part of the signal path, no cross-axis sensitivity will result. When vibrated in the Z-direction the voltage generated in the two pz-elements will – seen from the charge amplifier – cancel each other. Therefore, no signal will be generated in the X-



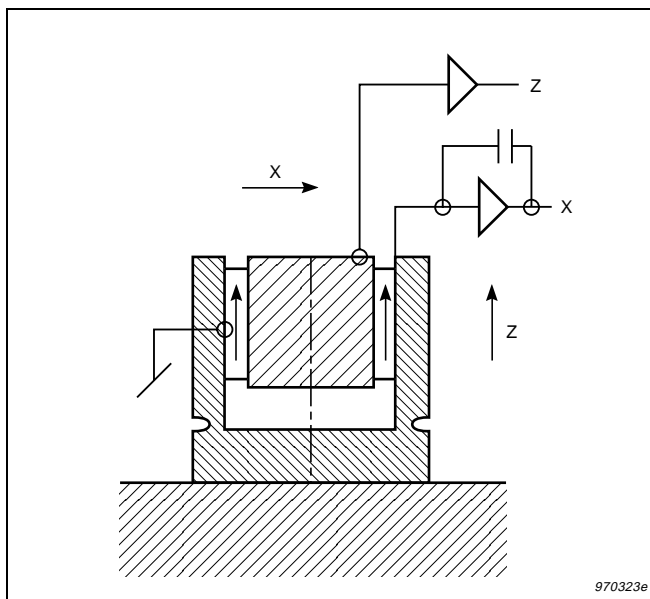

Fig. 4. Sketch of accelerometer with sensitivity in two directions

channel. Similarly when vibrated in the X-direction, the signals generated in the pz-elements will – seen from the voltage amplifier – cancel each other and no signal is generated in the Z-channel. Thus, the two channels are completely separated.

It is important that the X-signal is connected to a “virtual zero” input (charge amplifier), and the Z-signal is connected to a high input impedance (voltage amplifier). It is, of course, also important that the two pz-elements have exactly the same sensitivity and capacity.

## Triaxial accelerometer

In Fig. 5 an example is shown where this principle has been used to design a triaxial accelerometer. The design in Fig. 4 has been extended with two extra arms to form the third axis (the Y-axis) perpendicular to both the X- and the Z-axis. The sketch also shows a clamping ring which clamps the arms, the pz-elements and the mass together.

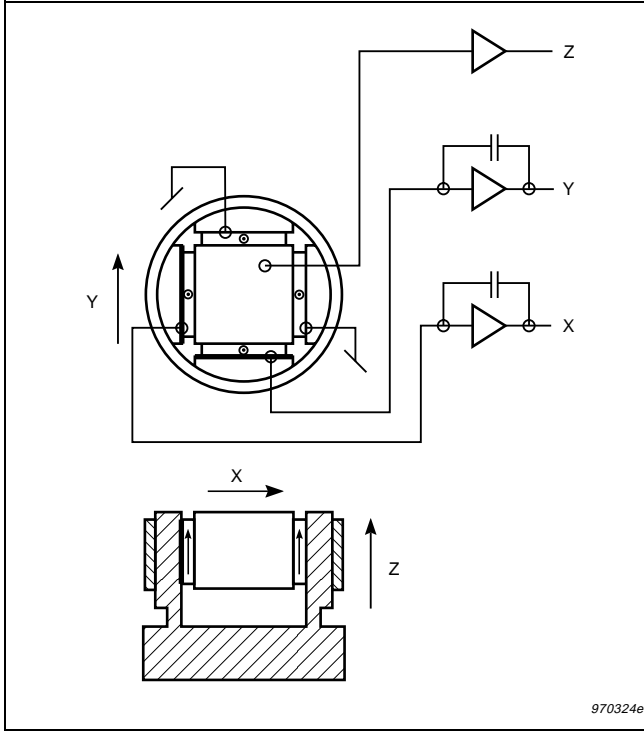

Fig. 5. Sketch of triaxial accelerometer

The Z-axis still works according to the “normal” shear accelerometer principle, whereas both the X- and the Y-axes work according to the shear-beam principle. The hinges which carry the four arms must now be flexible in the X- as well as the Y-direction.

Again, cross-axis sensitivity will be avoided when the X- and the Y-signals are connected to charge amplifiers and the Z- signal is connected to a high input impedance (voltage amplifier).

One advantage of building a triaxial accelerometer according to this principle is that all three axes have the same centre of gravity. In addition, it is obvious that it has far fewer parts than one built according to the traditional principles where three single axial units are mounted with their axes perpendicular to each other in a common housing.

However, a further reduction of parts can be achieved. From Fig. 5 it can be seen that all four pz-elements have their axes of polarisation in the Z-direction. Therefore, the idea arose that it might be possible to replace them with one pz-element in the shape of a block with a centre hole for the mass. Furthermore, if this “block” was made cylindrical, a standard pz shear ring could be used. Also the cylindrical shape would make the manufacturing of arms and central mass easier.

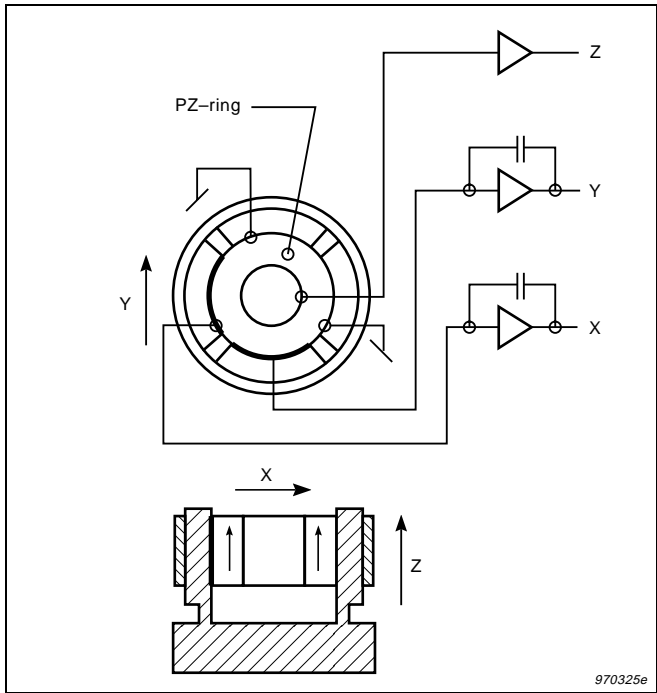
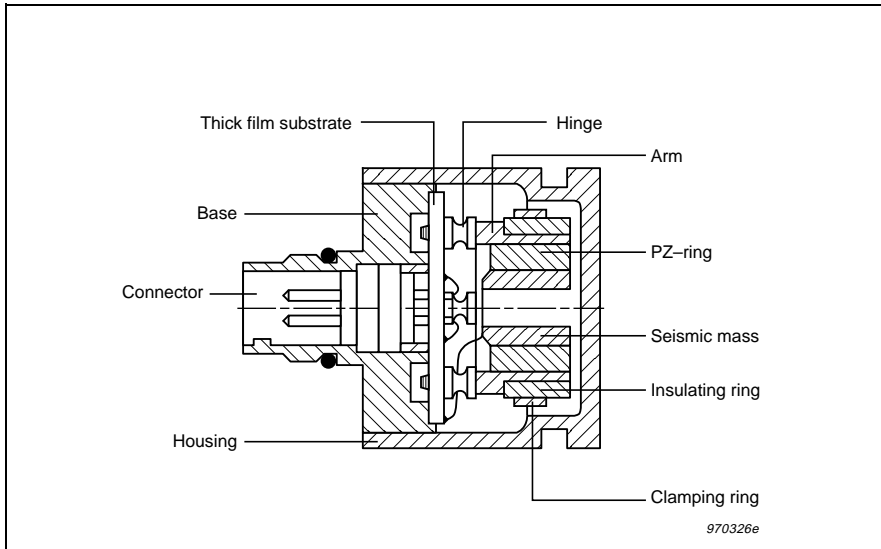

Fig. 6. Sketch of triaxial accelerometer with one pz-ring

A sketch of such an accelerometer is shown in Fig. 6. As seen, the four plane pz-elements have been replaced by one pz-ring polarised in the axial direction, and the four arms are now sectors of a cylinder. Although it looks quite different from the accelerometer in Fig. 5, the working principle is exactly the same.

The charge sensitivity of the X- and Y-channels can still be calculated from the formula given for Fig. 3a. Again M is the total mass above the hinges, i.e., the mass of all four arms, the pz-ring and the central mass. This is an important point as it makes the design very sensitivity/weight efficient.

A cross-sectional view of a practical realisation of a triaxial accelerometer made after this principle is shown in Fig. 7.



*Fig. 7. Cross-sectional view of practical solution of a triaxial accelerometer according to the shear-beam principle*

This accelerometer has the following parameters:

- Total mass above hinges:  $3.83 \times 10^{-3} \text{ kg}$
- Distance between opposite hinges: 9.2 mm

Orthogonal distance between plane of hinges and centre of gravity of mass: 4.2 mm

Piezoelectric constant  $d_{15}$  (PZ 23): 400 pC/N

From these parameters the charge sensitivity in the X- and the Y-directions can be calculated:

$$\frac{Q_x}{a} = \frac{Q_y}{a} = d_{15} \times M \times \frac{L}{h} = 400 \times 3.83 \times 10^{-3} \times \frac{4.2}{9.2} = 0.669 \text{ pC/ms}^{-2} \quad (6)$$

which is in perfect agreement with the measured specification shown below.

## Achieved Specifications

The shown accelerometer has the following specifications:

Sensitivity:

measured directly at pz-ring:

X and Y: 0.7 pC/ms<sup>-2</sup>

Z: 1.3 mV/ms<sup>-2</sup>

measured at output of amplifiers:

X and Y: 10 mV/ms<sup>-2</sup>

Z: 10 mV/ms<sup>-2</sup>

Mounted resonance frequency:

X and Y: 9 kHz

Z: 12 kHz

Cross-axis sensitivity: < 5%

Dimensions: 17 × 17 × 14.5 mm

Weight: 15 gram

## Concluding remarks

It has been proved that it is possible to design a triaxial piezoelectric shear accelerometer using a single pz-ring. The design has relatively few parts and is very compact. It also has the advantage that the three axes have a common centre of gravity. It has a high sensitivity/mass ratio because the total mass of the sensor element including arms, clamping ring, etc., constitute the active mass.

# A Simple QC Test for Knock Sensors

*S. Gade, S. Møllebjerg Matzen, H. Herlufsen,*

## Abstract

A simple set-up for quick and purely electrical QC testing of knock sensors is described in this paper. The main goal is to measure the “impedance” frequency response function of the sensors. The advantages of the test procedure described in this paper are as follows: Simple “pseudo” one channel measurement, from the operator’s point of view. Electrical testing, i.e. no need for shakers, power amplifiers, elaborate fixtures etc.. Pulse excitation, thus very fast — in the order of 100 ms for one measurement test. No averaging needed. Standard frequency response function display is used, whereby no complex postprocessing is required. The only requirement is a small junction box with the necessary transformer and some electronics. The power supply for the junction box is fed from the analyzer. The testing method can be extended to other types of transducers such as accelerometers.

## Résumé

Cet article décrit une installation simple pour un test de contrôle qualité rapide et purement électrique de capteurs d’accélération pour les moteurs à combustion. Le but principal est de mesurer la réponse en fréquence “impédance” des capteurs. Les avantages de la procédure décrite sont les suivants : une simple mesure “pseudo” monovoie (du point de vue de l’opérateur) ; Test électrique, c’est-à-dire sans excitateurs, amplificateurs de puissance, dispositifs complexes, etc.; Excitation impulsionnelle très rapide (de l’ordre de 100 ms par mesure d’essai) ; Pas de moyennage requis ; Affichage standard de la fonction de réponse en fréquence ( pas de post-traitement compliqué requis). Le seul élément nécessaire est une petite boîte de jonction avec transformateur et circuits électroniques. La boîte de jonction est alimentée par l’analyseur. Cette méthode de test peut être élargie à d’autres types de capteurs, notamment les accéléromètres.

## Zusammenfassung

Dieser Artikel beschreibt eine einfache Anordnung zur schnellen und rein elektrischen Qualitätsprüfung von Klopfensoren. Das Hauptziel besteht darin, den "Impedanz"-Frequenzgang der Sensoren zu messen. Die beschriebene Prüfmethode besitzt folgende Vorteile: Einfache "Pseudo"-Einkanalmessung aus der Sicht des Bedieners. Elektrische Prüfung, d.h., keine Shaker, Leistungsverstärker, komplizierte Halterungen etc., erforderlich. Durch Verwendung von Pulsanregung sehr schnell – in der Größenordnung von 100 ms für einen Meßtest. Keine Mittelung erforderlich. Es wird die Standard-Frequenzgangdarstellung verwendet, d.h. keine komplexe Nachverarbeitung erforderlich. Benötigt wird lediglich ein kleiner Anschlußkasten mit dem notwendigen Transformator und etwas Elektronik. Der Anschlußkasten wird vom Analysator versorgt. Die Prüfmethode läßt sich auf andere Sensoren wie Beschleunigungsaufnehmer erweitern.

## Introduction

A knock sensor is an acceleration transducer for ignition systems, which incorporate knock control. A knock sensor uses a piezoelectric element to measure the inertial forces exerted upon a seismic mass. The typical frequency range and vibration amplitude are from 5 kHz to 15 kHz and approximately 100 m/s<sup>2</sup> respectively.

Internal-combustion engines are damaged by combustion knock, so knock control serves to prevent knocking under all operating conditions. The knock sensor is installed in a location, which is selected for its optimum knock-detection properties.

There are resonant and non-resonant types of knock-sensors. A resonant sensor has a high frequency selectivity and gives a high output in the case of knocking. In general, there is a first mode frequency between 5 kHz and 10 kHz and a second mode frequency above 10 kHz. Which mode is excited depends upon the engine type. This type of sensor has an excellent signal to noise ratio for engine speeds from 1000 RPM to 5000 RPM.

A non-resonant type has a flat frequency characteristic. Therefore this is a general purpose sensor, which is often mounted on to the cylinder block. Ref. [1].

Knock sensors are inexpensive transducers and widely used in the automotive industry. Therefore there is a need for a simple and inexpensive method for QC production-testing of these transducers.



The piezoelectric charge-mode knock-sensor behaves like a single degree of freedom spring-mass system. The spring is the piezoceramic crystal and the mass is the seismic mass mounted on the crystal. The mounted resonance of the sensor is the resonance of this internal spring-mass system only, that is, the resonance when the transducer base is firmly mounted to a mass much larger than the seismic mass. Due to the simplicity of this structure, the mounted resonance frequency signature provides an indication of the integrity of the structure. If the mounted resonance frequency signature is “normal”, then the sensor is intact and it is reasonable to infer that the charge sensitivity in picoCoulomb per g or per  $m/s^2$ , at all frequencies is within specifications. Thus the intention of this method is not to carry out an absolute gain calibration of the sensors, but to perform a quick check. In this paper it is also demonstrated that testing the unmounted resonance frequency is sufficient due to the relatively heavy base of the specific knock sensors tested in these measurements.

In the following a procedure for a simple test method is presented. The method relies on a derived reciprocity principle, i.e. instead of a mechanical input causing an electrical output we apply an electrical input causing a mechanical response, which we on the other hand do not measure directly but rather measure the derived electrical response due to this mechanical response. Thus the method is useful as mentioned earlier for QC production testing of knock-sensors.

## Test Set-up

The sensor tests have been performed using a dual channel version of the Brüel & Kjær Multichannel Analysis System Type 3550. A schematic diagram of the set-up is shown in Fig.1.

The test principle is as follows. A short electrical pulse, from the voltage generator of the analyzer, can be used as a test signal. The pulse is fed into the transducer via a transformer, which decouples the excitation and the response signal, as shown in Fig.1. The transducer is connected to one of the charge inputs of the analyzer via the junction box, in this case ch. B. The response signal from the transducer, which acts as a current generator, is measured in this channel. The generator excitation signal is used “internally” in the analyzer for equalization of the response spectrum of the knock sensor, in this case the generator signal is directly connected to ch. A.

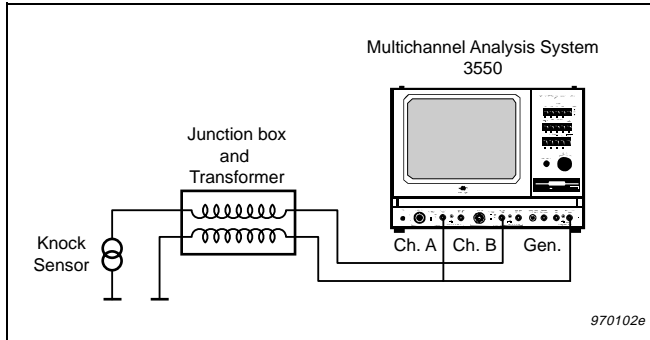

*Fig. 1. Schematic diagram of test set-up*

The frequency response is calculated as the ratio between the measured spectrum of the transducer response and the generator signal, Ref.[4]. This eliminates any undesirable influence from the shape of the input spectrum.

Since the test signal is a short pulse, it is recommended to use a short transient weighting function, which is long enough to include the full pulse including any ringing due to antialiasing filtering as well as the ringing of the response signal due to the resonances of the test object itself. Thus the length of the weighting function may be longer in the response channel than in the excitation channel. Some leading and trailing tapering (not shown) have been applied in order to minimize leakage errors due to truncation. These transient weighting functions will improve the signal to noise ratio in the analysis compared to the use of rectangular (i.e. no) weighting. In this case the S/N improvements are 12 dB and 6 dB for channel A and channel B respectively. Ref. [3].

Since the property of primary interest is the resonance frequency for the sensor under test, 22.4 Hz highpass filters have been chosen in the input amplifier. The Brüel & Kjær Multichannel Analysis System Type 3550 measurement set-up parameters are shown below.

Setup 1			
Measurement:	DUAL-CH SPECTRUM AVERAGING 800 lines		
Trigger:	CH.A	Slope: +	Level: +0.10* max input
Delay:	Trig>A: -3.998 ms		
Averaging:	EXP	1 AUTO	REJECT overload
FREQ.SPAN:	25.6 kHz	Δf: 32 Hz	T: 31.3ms Δt: 15.3us
WEIGHT CH. A	TRANSIENT		Shift: 3.601 ms
	Length: 1.999 ms		
Weight ch. B;	TRANSIENT		Shift: 3.601 ms
	Length: 7.996 ms		
ch. A: 150 mV	DIRECT	/-22.4 Hz	-/ON 1V/V
ch. B: 1.5nC	ACC	/-22.4 Hz	-/ON 1V/V
Generator:	UDW.PULSE		0.0dB DC: 0uV
	CONT	WHITE	LF-filter: ON

All other settings are default values.

## The Test Signal

The test signal is as mentioned earlier a pulse generated by the internal generator of the analyzer. The pulse is a gated square wave. This ensures that the main energy of the signal is concentrated at “higher” frequencies, rather than at DC. An example is shown in Fig.2.

Using a 25 kHz frequency range the optimum duration of the pulse is 60 μs in order to have maximum energy in the middle of the frequency span of interest, i.e. from 5 kHz to 20 kHz using a 25 kHz measurement range. The time duration corresponds to a length of 4 samples. If the frequency range is increased/decreased the pulse duration must be decreased/increased accordingly in terms of absolute time, but not in terms of the number of samples. The “standard” generated pulses have positive amplitudes and can have rectangular, Hanning or Gaussian shapes. Thus the pulse used for this test is implemented as a User Definable Waveform (UDW). A User Definable Waveform can either be a measured signal or spectrum or be defined via a mathematical expression, which is then displayed as a User Definable Display Function (UDDF). The displayed function, whether measured or mathematically defined is then moved to the User Definable Waveform generator by a move command. The definition of the User Definable Display Function named, PULSE is given in Eq.(1). This User Definable Display Function is then as mentioned earlier moved to the User Definable Waveform generator.

```

USER-DEFINABLE DISPLAY FUNCTION. PULSE

Graph Displayed as: TIME (Real, V)                                Unit: V

pulse =                    amplitude * double_bongo
AMPLITUDE =                60.00 m;
double_bongo =            bongo - rotate (bongo, width)
bongo =                    window (ones, start, width)
WISTH =                    2.000 ;
START =                    10.00                                Eq.(1)

```

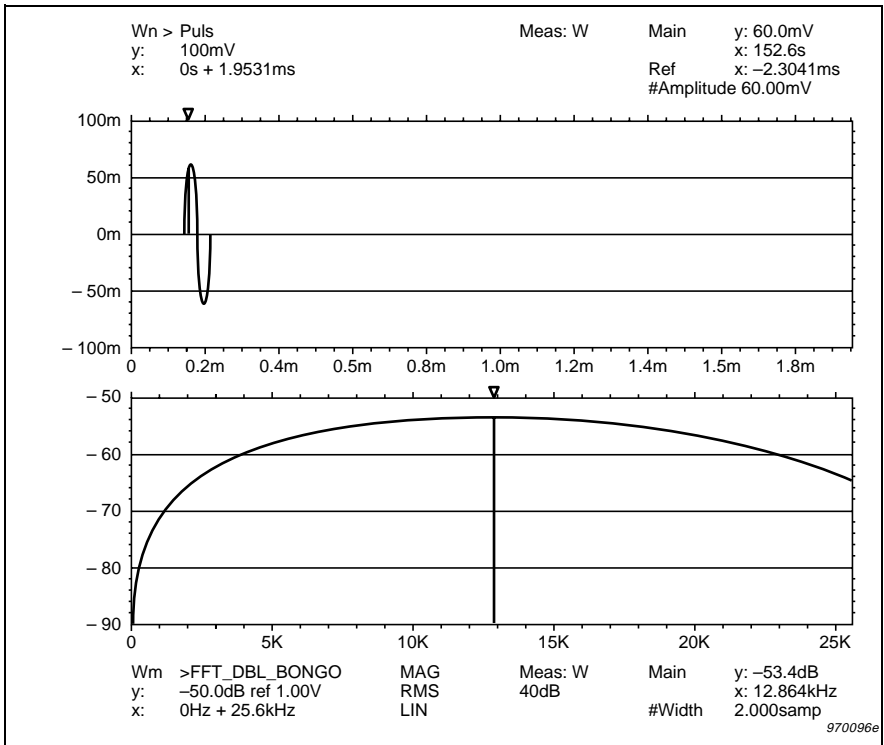

Fig. 2. The pulse used for testing over a 25.6 kHz frequency range and its corresponding spectrum shown using a 40 dB display range

The generator also includes a wide range of “standard” signals, such as random, burst random, pseudo-random, periodic random, single or dual fixed or swept sines and pulses of various shapes and lengths.

A pulse (called bongo) of two samples (width) with 1 V positive amplitude (ones) is located in start element 10 (and 11). By use of the rotate command a second pulse with negative amplitude is created, but shifted (rotated) by the width of two samples. Thus, this combined pulse is optimized for use in any baseband frequency range. The amplitude factor of 0.06 relative to 1 V (see Fig. 2, upper) is used in order to avoid overload and distortion in the chosen transformer. Amplitude, Width and Start parameters are User Definable Variables (UDVar) for ease of alteration and these parameters are located in the cursor set-ups as shown in Fig.2.

## Test Results for some Knock Sensors

A typical test result from a resonant type knock sensor is shown in Fig. 3. The two results are from a 102.4 kHz range and a 12.8 kHz range, respectively.

Due to low excitation signal level at low frequencies for this particular test signal, measurements or rather the numerical calculations at frequencies below 500 Hz are unreliable and have been blanked out. The blank limit is a selectable parameter in the analyzer. If low frequencies rather than the resonance frequency is of primary interest, a different test signal, for example, a rectangular pulse, which is a standard generator waveform, should have been used, but as stated earlier the typical range of interest is from 5 kHz to 20 kHz.

In order to develop a realistic test method the transducer must normally be mounted on a heavy seismic mass. In this case a 4 kg block of steel has been used. This is due to the well-known fact that the unmounted resonance frequency is higher than the mounted resonance frequency. Ref. [2]. Fig. 4 shows this difference. The first resonance is hardly changed basically due to the fact that the sensor under test has a relatively heavy base, while the second resonance, in case of unmounted, is increased in frequency by 1.2%, the level is increased by 4.1 dB and the relative damping is decreased by a factor of 2 from 0.65% to 0.35% of critical damping. Thus for testing the frequency location of the first resonance, unmounted transducers can be used, which will increase testing speed.

A typical example of a test on a non-resonant knock transducer is shown in Fig. 5.

For the non-resonant type it can be seen that there are no distinct resonances in the mounted case. Actually the non-resonant sensor is best suited for

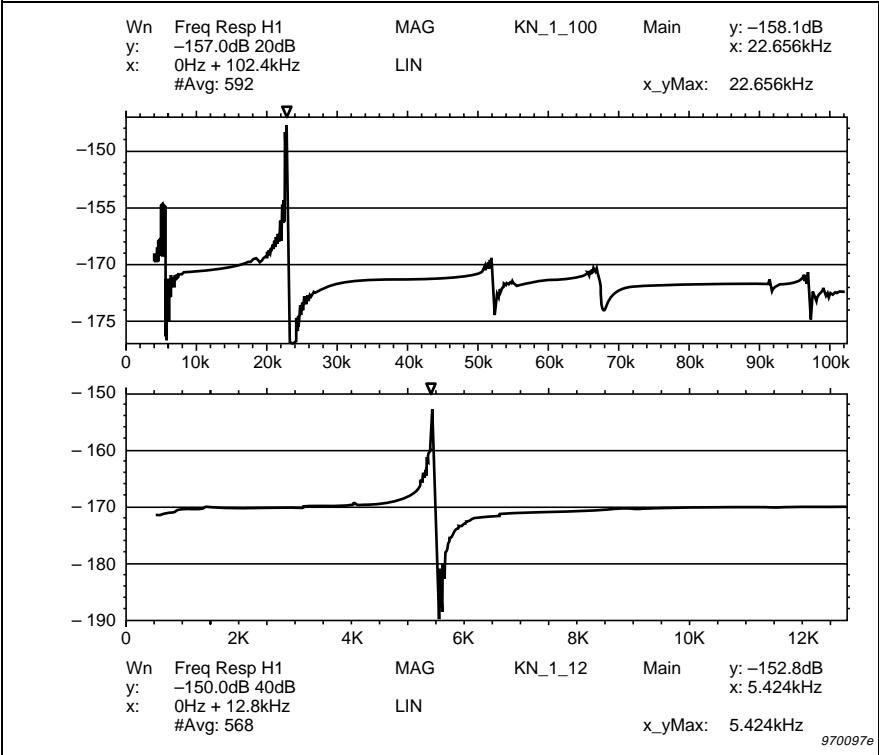

Fig. 3. Test of a resonant Knock sensor using different frequency ranges

unmounted QC testing since this case shows a clean and pronounced resonance.

### Verification of the Test Procedure using a Standard Accelerometer

The described test has also been applied to a “well-known” object, namely, Brüel & Kjær Charge Accelerometer Type 4382. The results are in full agreement with a traditional dual channel (mechanical input/electrical output) shaker test, except for the fact that the absolute sensitivity ( $\text{pC}/\text{m}/\text{s}^2$ ) is not measured. Note that the method can only be used on a transducer that exhib-

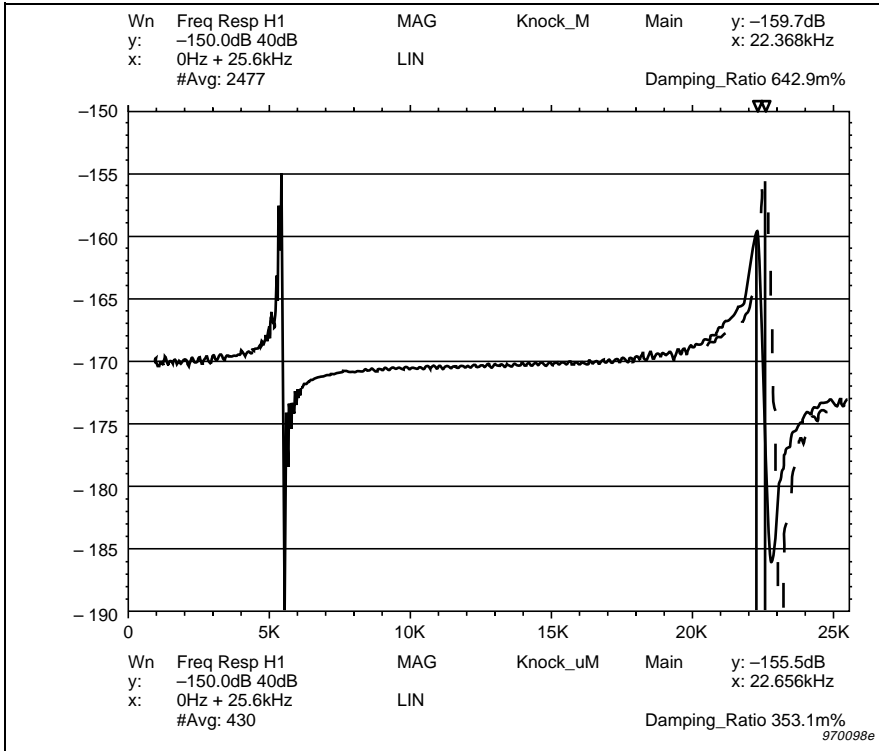

Fig. 4. Superimposed graph displaying the FRF's of a resonant-type knock sensor mounted (upper graph) and unmounted (lower graph)

its reciprocity, thus transducers with built-in electronics such as line-drive DeltaTron accelerometers cannot be tested using an electrical input since this will not cause a mechanical response.

Fig.6 shows the test results from a mounted accelerometer in the upper graph and an unmounted accelerometer in the lower graph. The sensitivities at low frequencies are identical. Only the position of the resonance has shifted.

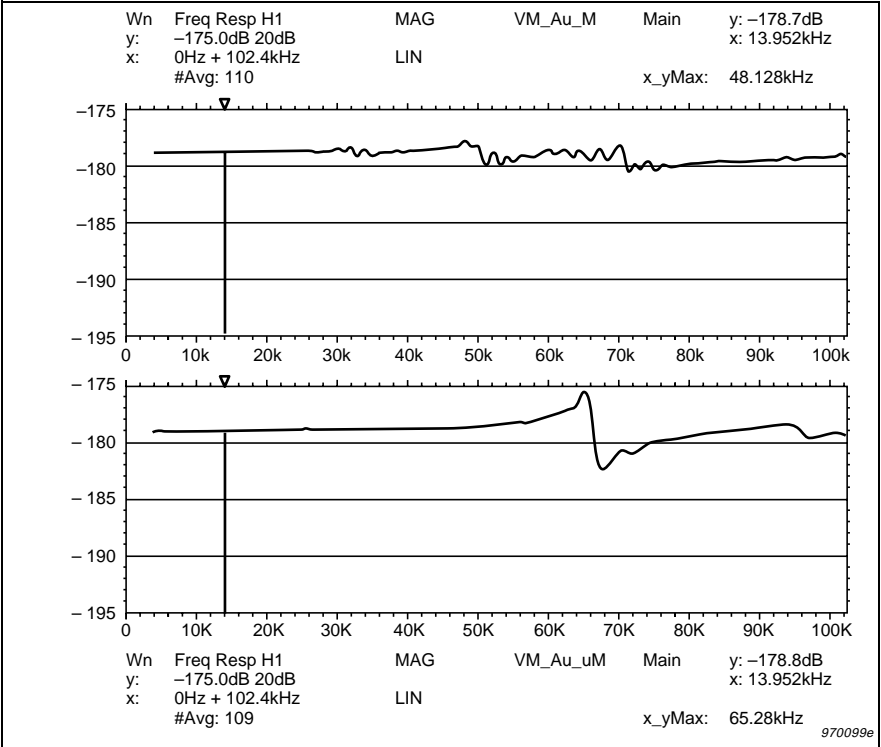

Fig. 5. Non-resonant knock sensor measured when mounted (upper graph) and unmounted (lower graph)

### Automated QC testing

The automated QC testing can be performed in different ways. The most simple method is to let the analyzer search for the resonance frequency and give good/no good indication as a User Definable Auxiliary Information (UDAI) readout depending on whether the resonance frequency is within specifications or not. Another simple but more elaborate method still completely contained within the analyzer would be to set up tolerance curves (so-called profiles) which the measured frequency response is compared against. These tolerance curves could even be horizontal straight lines if the measured fre-



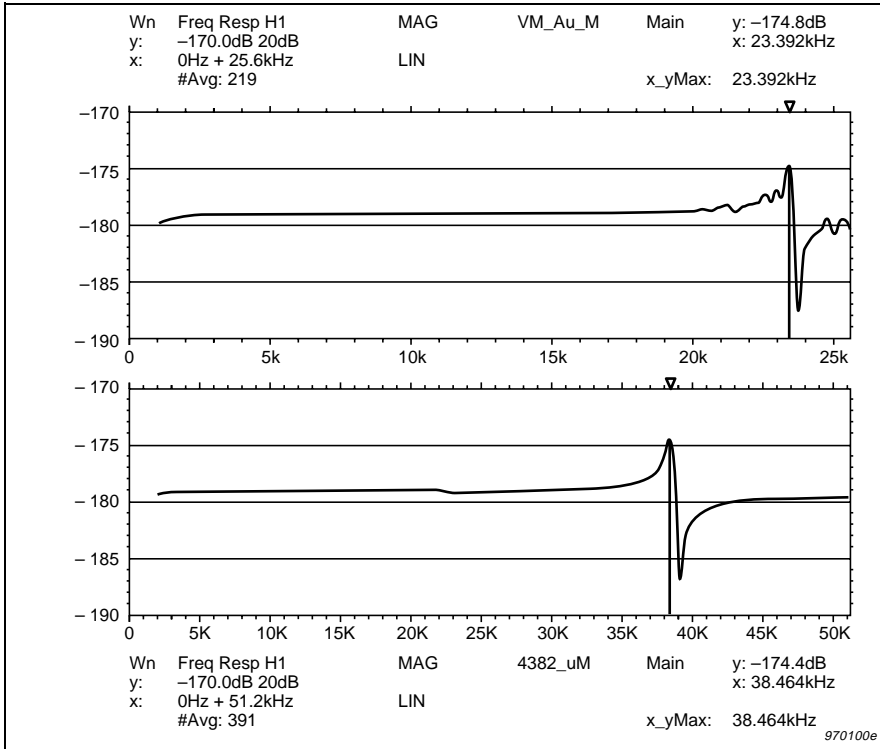

Fig. 6. Brüel & Kjær Accelerometer Type 4382 tests, mounted (upper) and unmounted (lower)

quency response is equalized by the frequency response of a “good” reference knock sensor.

Many more advanced methods using signal classification by the use of, for example, Neural Networks are well described in literature and the discussion of signal classification is outside the scope of this paper.

## Conclusion

The results show that it is possible to use the proposed method for the testing of mounted, as well as unmounted resonant types of knock sensors. An

unmounted test procedure might reduce the testing time considerably, since no mounting of the sensor is required. The technique may also be used for non-resonant types since these types show a clear resonance, when unmounted.

The advantages of this test procedure compared to traditional vibration excitation methods are as follows:

- 1) Simple "pseudo" one channel measurement, from the operator's point of view.
- 2) Electrical testing, i.e. no need for shaker, power amplifier, elaborate fixture, etc.
- 3) Pulse testing, thus very fast – in the order of 100 ms for one measurement.
- 4) No averaging is needed (although some averaging has been applied in the examples).
- 5) No influence of ringing of antialiasing filters (due to the fact that dual channel calculations are performed).
- 6) No (generator) impedance load of the knock transducer.
- 7) Standard frequency response function display is used. Therefore no complex (computer) postprocessing is needed.
- 8) No need for switching networks, for the signal generator or the analyzer inputs.

The only requirement is a small junction box with the necessary transformer and some electronics. The power supply for the junction box used is supplied by the analyzer.

The principle described in this paper is similar to the patented "Accelerometer Mounted Resonance Test" found in the Brüel & Kjær Measuring Amplifier Type 2525.

## References

- [1] *"Automotive Handbook"*, (3rd Ed.), BOSCH, ISBN 1-65091-372-X
- [2] *"Piezoelectric Accelerometers and Vibration Preamplifiers"*, Brüel & Kjær Handbook, BB 0694
- [3] Gade, Herlufsen: *"Windows to FFT Analysis"*, (Brüel & Kjær Technical Review Nos. 3 & 4, 1987.)
- [4] Herlufsen: *"Dual Channel FFT Analysis"*, (Brüel & Kjær Technical Review Nos. 1 & 2, 1984.)

# Torsional Operational Deflection Shapes (TODS) Measurements

*Svend Gade, Kevin Gatzwiller, Henrik Herlufsen*

## Abstract

This article describes the concept and basic technique of measuring torsional operational deflection shapes using a laser-based torsional vibration meter, a dual-channel FFT analyzer and operational deflection shapes software running on a PC.

Torsional Operational Deflection Shapes (TODS) is defined similar to ODS (Operational Deflection Shapes), with the exception that TODS designates the operational deflection shapes of structures vibrating in a rotational, or angular, degree of freedom. Thus the TODS measurements can be applied to rotating shafts and the results of such a measurement are shown. In some cases it may be of great benefit to apply order tracking and/or synchronous time domain averaging techniques in order to avoid smearing and reduce noise problems.

## Résumé

Cet article décrit le principe et la technique de base pour les mesures des modes de déformation angulaire en fonctionnement (déformations par torsion) à l'aide d'un mesureur de vibrations angulaires par effet laser, d'un analyseur FFT bicanal et d'un logiciel PC de calcul de déformées en fonctionnement.

Une déformée angulaire en fonctionnement (Torsional Operational Deflection Shapes = TODS) se définit similairement à une déformée en fonctionnement (Operational Deflection Shapes = ODS), à ceci près que TODS désigne la déformation de structures vibrant selon un degré de liberté rotationnel, ou angulaire. Ce type de mesures peut donc être appliqué aux arbres en rotation. Les résultats de telles mesures sont montrés ici. Dans certains cas, il peut être avantageux de mettre en œuvre une analyse d'ordre et/ou une technique de moyennage synchrone pour éviter un étalement des composantes et les problèmes dus au bruit.

# Zusammenfassung

Dieser Artikel beschreibt das Konzept und die Grundtechnik für die Messung von Dreh-Betriebsschwingformen mit einem Drehschwingungsmesser auf Laserbasis, einem Zweikanal-FFT-Analysator und Betriebsschwingform-Software auf einem PC.

Dreh-Betriebsschwingformen (Torsional Operational Deflection Shapes, TODS) sind analog den Betriebsschwingformen (Operational Deflection Shapes, ODS) definiert, mit dem einzigen Unterschied, daß TODS die Betriebsschwingformen von Strukturen beschreiben, die mit einem Rotations-Freiheitsgrad schwingen. TODS-Messungen lassen sich daher auf rotierende Wellen anwenden. Die Ergebnisse einer solchen Messung werden vorgestellt. In manchen Fällen kann es sehr vorteilhaft sein, Ordnungsanalyse und/oder synchrone Zeitsignalmittelungstechniken anzuwenden, um "Verschmieren" und Störsignalprobleme zu vermeiden.

## Introduction

Operational Deflection Shapes (ODS), designates the periodic motion pattern of a vibrating structure at a specific frequency and under a particular stationary, operating condition. An ODS is an observation, or visualization, of a particular dynamic behaviour. ODS of a vibrating structure can provide very useful information to aid in the understanding of the dynamic behaviour of a machine, a component or an entire structure, in particular when searching a solution to a dynamic problem [1].

Torsional Operational Deflection Shapes (TODS) are defined similar to ODS, with the exception that TODS designates the operational deflection shapes of structures vibrating in a rotational, or angular, degree of freedom. Determining the ODS, or TODS, of a structure requires the measurement and analysis of the response signals from the vibrating structure.

## Measuring Angular or Rotational Vibration

Measurement of angular vibration, particularly in the field, has heretofore posed several practical problems. Conventional angular vibration transducer systems have required the insertion of sensors such as strain gauge sensor modules, gear tooth wheels or optical encoders requiring the "disecting" of shafts unless located at a shaft end, or have been restricted to accessible por-

tions of the shaft system. Signal conditioning and phase demodulation processing add to the problems by limiting the frequency range and dynamic range of the measurement. Furthermore, calibration is usually difficult to perform [2].

The Brüel & Kjær's Torsional Vibration Meter Type 2523, provides a fast and easy means of measuring angular vibrations anywhere on a visible part of a rotating shaft, fulfilling one of the most important demands for measuring torsional operational deflection shapes, namely the ability to move the angular vibration transducer to a set of measurement positions.

The Torsional Vibration Meter Type 2523 is based on a patented dual laser beam principle where two laser beams are radiated from a laser transducer and pointed towards the shaft, rotating with at least 30RPM (optionally down to 5 RPM).

The amount of measured Doppler shift in the two laser beams is proportional to the rotational speed, which is measured directly in RPM.

Any angular vibrations in the shaft, superimposed onto the steady rotational speed of the shaft, will be detected as well, causing the signal on the detector to be frequency modulated at the same frequency as the frequency of the measured angular vibration.

The Torsional Vibration Meter requires retro-reflective tape to be attached around the shaft [3].

## Measuring Torsional Operational Deflection Shapes

Expanding a normal, i.e. a one-plane angular vibration measurement with a TODS measurement can be extremely useful in many applications.

The most important benefit of a TODS measurement is that it provides an animated picture of the torsional deformation at critical frequencies (typically a harmonic component close to a torsional natural frequency) under operating conditions.

A visualization of the torsional deformation shape provides a better understanding of the vibrational problem and consequently, this can help in creating the basis for a better solution to the problem.

## Applications of TODS

Torsional vibrations in rotating shafts are well-known as sources of numerous vibration problems. Typical problems within the automotive industry and the marine engine industry include:

Lack of power-train smoothness and quietness, gear rattle noise, reduced engine performance and reduced reliability.

### *Lack of power-train smoothness and quietness*

The shafts in the drive-train of passenger cars are excited into torsional vibrations by the inertial and gas forces of the engine, the cardan joints and the gear mesh. Torsional resonance phenomena in the driveshaft, halfshaft, etc., can create wear and fatigue problems along with reduced passenger compartment comfort [4].

### *Gear rattle noise*

In an automobile, the inherent rotational fluctuations (angular vibration) of the combustion engine are transmitted to the input shaft of the gearbox thereby generating rattle noise [5], which is a significant contributor to the overall noise level in the passenger compartment.

### *Reduced engine performance*

Torsional vibrations occurring at the crankshaft are one of the major sources of combustion engine vibration leading to increased mechanical shear stresses and higher noise levels radiated from the engine [6].

### *Reduced reliability of ship propulsion systems*

Shafts in a marine propulsion system are excited to torsional vibrations by the inertia and gas forces of the engine. Again, the common problems associated with this include wear and excessive mechanical shear stresses in the shafts with the possibility of shaft failures. Obviously, these vibrational problems often make the measurement and analysis of torsional vibration play an important role when designing against (or trouble shooting) vibrational problems in rotating machinery.

## Equipment For Measuring A Basic Torsional Operational Deflection Shape

The Torsional Vibration Meter Type 2523 measures the angular vibrations in a single plane giving a calibrated output in millidegrees/second (angular

velocity) or in millidegrees (angular displacement). Thus, when measuring the Torsional Operational Deflection Shape, subsequent measurements must be performed at different planes along the shaft where the phase of the torsional vibration between the different planes must be determined as well. A Brüel & Kjær Tacho Probe MM0024 is used as a reference transducer to obtain this phase information. Fig.1 shows the set-up.

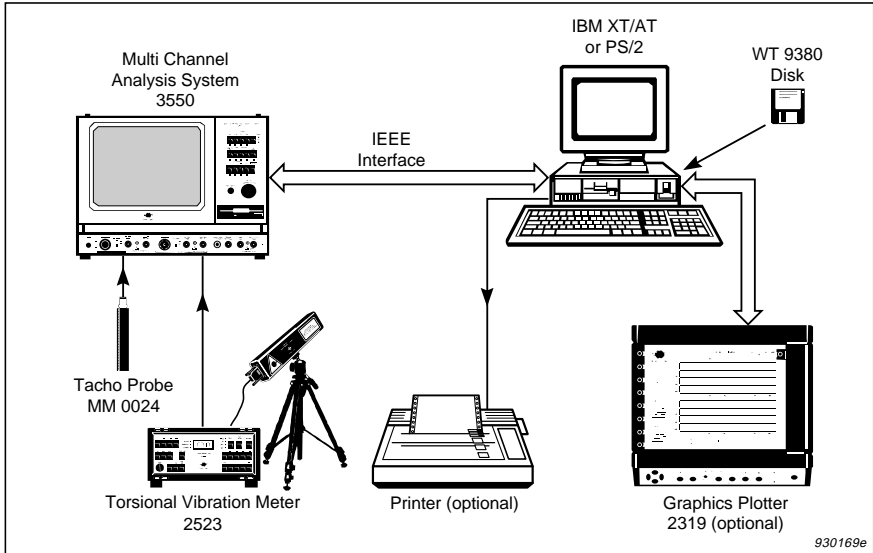

*Fig. 1. TODS set-up with instruments*

The Torsional Operational Deflection Shape measurement is therefore performed by fixing and aiming the tacho probe at an arbitrary point on the shaft and moving the Torsional Vibration Meter Type 2523 along the shaft, measuring at different positions. At each point, the Torsional Vibration Meter Type 2523 will provide the torsional vibration amplitude (in millidegrees or degrees/second depending upon the mode of operation). Channel B of the Multichannel Analysis System Type 3550 is connected to the AC output of the Torsional Vibration Meter Type 2523 and Channel A is connected to the Tacho Probe MM0024.

At the frequency of interest, i.e. the torsional natural frequency being excited, the Complex Spectrum (i.e. phase assigned autospectrum) of the Multichannel Analysis System Type 3550 will provide the vibration amplitude as well as phase information. However, no manual data interpretation is required: the Personal Computer, running the WT9380 Operational Deflection Shapes Software, is used for complete analyzer control, transfer of transmissibility data, data processing and deflection shape presentation (animation).

## Measurement Setup

A Torsional Operational Deflection Shapes measurement was performed on a thin steel shaft with two aluminium flywheels, rigidly mounted at the ends of the shaft. The shaft, symmetrically built and supported by six roller bearings, is made to rotate, at variable speed, by means of an electric motor. This mechanical system possesses a number of natural frequencies (in the translational as well as in the rotational degrees of freedom), of which the first torsional natural frequency is excited by two permanent magnets mounted in two of the bearing housings and two other magnets are positioned at equal distance, on one of the aluminium flywheels.

During rotation of the shaft the speed of rotation was fine-tuned to coincide exactly with the first torsional natural frequency, thereby creating a (stationary) torsional resonance situation. The torsional operational deflection shape was as shown in Fig.2, i.e. the two ends of the shaft have the same torsional vibration amplitude, but a phase difference of approximately  $180^\circ$ . The nodal point is found to be in the middle of the shaft due to the symmetrical design. Four measurement positions were defined as indicated in Fig.2.

## Measurement Results

The result of the direct TODS measurement, i.e. the absolute angular vibration measured at the four measurement positions and the relative torsional vibration between the four measurement positions, are shown in Fig.3 as a print-out from the WT9380 ODS-software. The TODS frequency is identified to be 17.0Hz within a "curvefit" bandwidth of 10 Hz and a resolution of 0.5Hz. The data type is velocity, since the output of the Torsional Vibration Meter is proportional to the angular velocity.

The DOF (Degree of Freedom) column specifies the four measurement positions. Due to the fact that cylindrical coordinates have been used the suffix 2



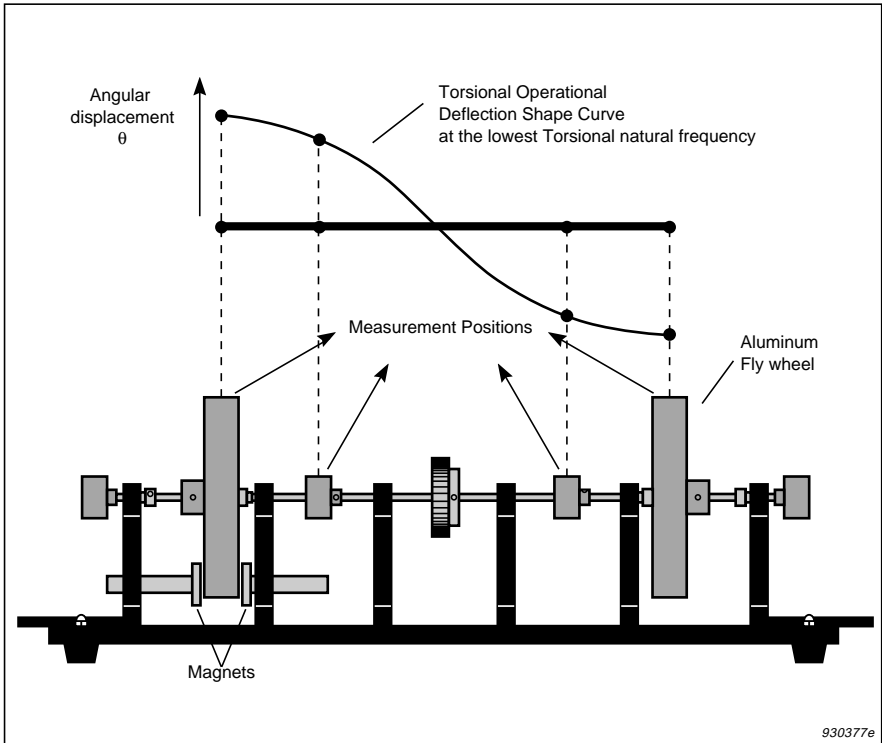

*Fig. 2. A thin steel shaft with two aluminium flywheels*

designates that the measurements are performed in a rotational degree of freedom.

Both relative as well as absolute numbers are displayed. Therefore it is easy to identify that DOF 4/2 shows the highest level of angular vibration corresponding to RMS values of 2.76 degrees displacement corresponding to 295 degrees/second velocity and 31 500 degrees/s<sup>2</sup> acceleration.

The scale factor can be changed if peak values or peak to peak values are preferred, or if a recalibration is needed. The phase indicates that DOF's 1/2 and 2/2 are approximately in opposite phase of DOF's 3/2 and 4/2.

Operational Deflection Shape # 1						Page: 1
Set #: 1		ODS Frequency: 17.00				
Center Freq.: 17.00		Bandwidth: 10.00				
Scale Factor: 1.000		Data Type: Velocity				
DOF	Relative		Absolute			
	Amplitude	Phase	Acceleration	Velocity	Displacement	
1/ 2	0.979	165.	30.9 K	289.	2.71	
2/ 2	0.470	168.	14.8 K	139.	1.30	
3/ 2	0.417	18.	13.2 K	123.	1.15	
4/ 2	1.000	0.	31.5 K	295.	2.76	

930517e

Fig. 3. Listing of the TODS values

The relative torsional vibration (amplitude and phase) between the measurement positions forms the basis for the computer to create the TODS animation, which is shown in Fig.4.

Using a simpler geometry, the animation can also be displayed as indicated in the upper part of Fig.2. For detailed information, see Ref. [7].

## TODS Measurement Combined With Order Tracking

Order Tracking, which is also possible with the Multichannel Analysis System Type 3550, can be used for concentrating each harmonic of the TODS into one frequency line only, thus avoiding any problems with smearing, leakage and picket fence effect errors. Although the frequency axis is rescaled into an order axis, the MM0024 Tacho Probe, now also being used to control the sampling rate of the analyzer, provides the necessary information for reading out the various orders in Hertz or RPM. This is a very useful technique if there are some speed variations of the rotating shaft, causing the rotational speed to drift between several FFT lines. The tacho probe must be connected to one of the measuring channels as shown in Fig.1.

A comparison of measurement without and with order tracking is shown in Fig.5. Fig.5a shows the level of the second harmonic found at 34 Hz to be 1.4 dB

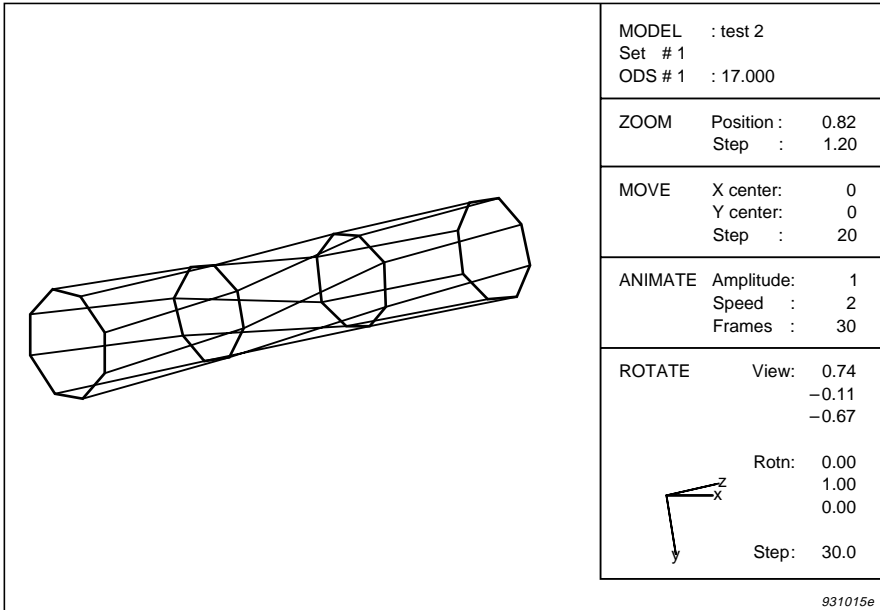

Fig. 4. Animated TODS at 17 Hz

lower than the level of the second order as shown in Fig.5b. This is due to the fact that the second harmonic in this case is found nearly midway between two FFT lines, thus yielding a picket fence effect (amplitude) error close to 1.42 dB which is the maximum error obtained using a Hanning weighting function.

## TODS Measurements Combined With Synchronous Time Domain Averaging

Signal Enhancement, which is also possible with the Multichannel Analysis System Type 3550, can be used for increasing the signal to noise ratio in the measurement. The data acquisition is directly triggered off the tachometer probe connected to one of the channels, or the trigger input.

Fig.6a shows the 17 Hz signal from the Torsional Vibration Meter. Fig.6b shows the same signal based on 10 synchronous time domain averages (called Signal Enhancement on the Brüel & Kjær analyzers). The signal to noise

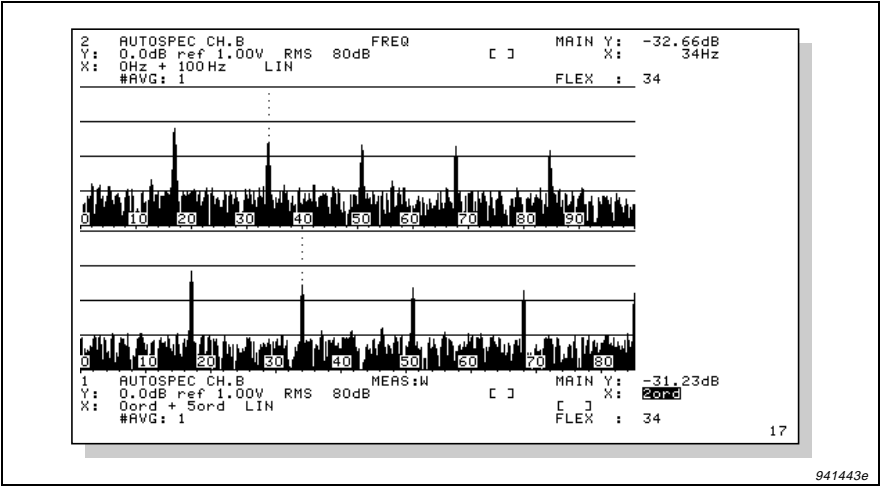

Fig. 5. a) TODS measurement using spectrum averaging  
 b) TODS measurement using spectrum averaging combined with order tracking

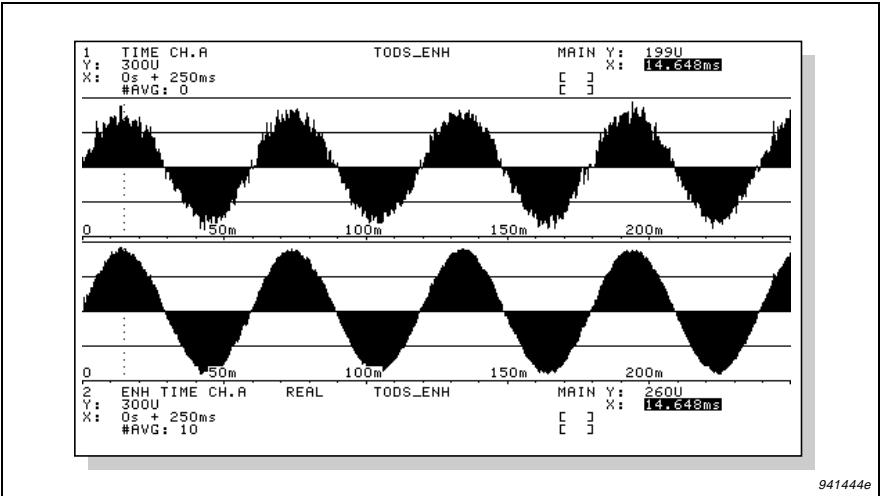
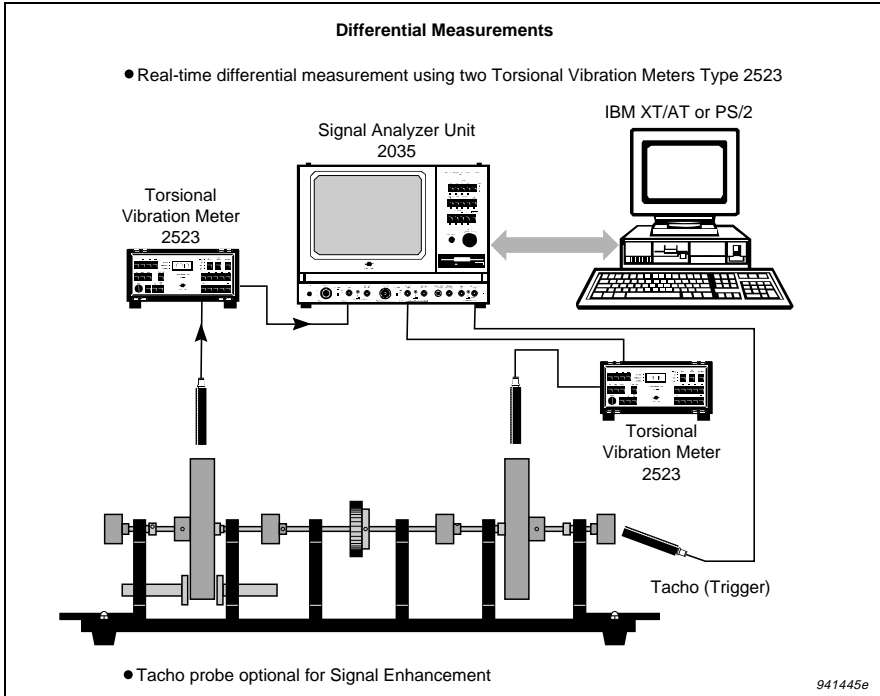

Fig. 6. a) Instantaneous time signal b) Enhanced time signal based on 10 averages

improvement is  $10 \log$  (number of averages), so 8–10 averages is suitable if exponential averaging is used in order to obtain a noise reduction of 9–10dB and still be able to trace some slightly non-stationary signals.



*Fig. 7. "Real time differential measurement of torsional "twist" using two Torsional Vibration Meters. The use of the tacho probe as a trigger is mandatory if Signal Enhancement is applied*

# Differential Measurements

Using two Torsional Vibration Meters Type 2523 as shown in Fig.7 and differential analysis of the two AC Signal Outputs in the Multichannel Analysis System Type 3550, a direct real-time measure of the “twist” between two planes on the shaft is obtained. This requires a simple User Definable Display Function, which is shown in Fig.8.

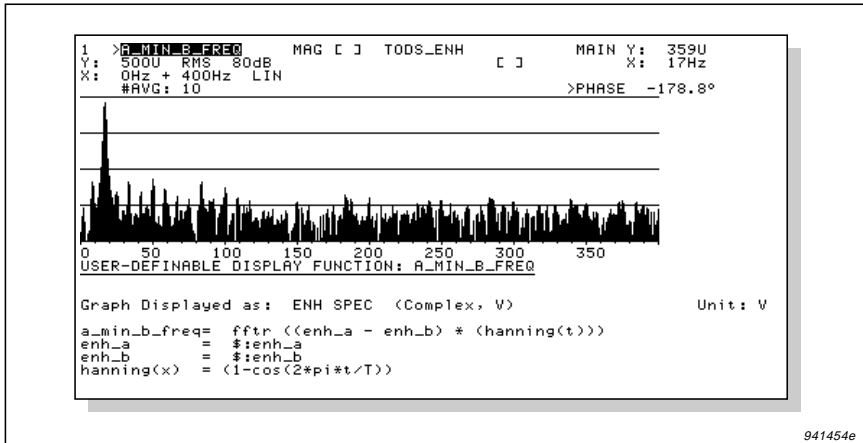
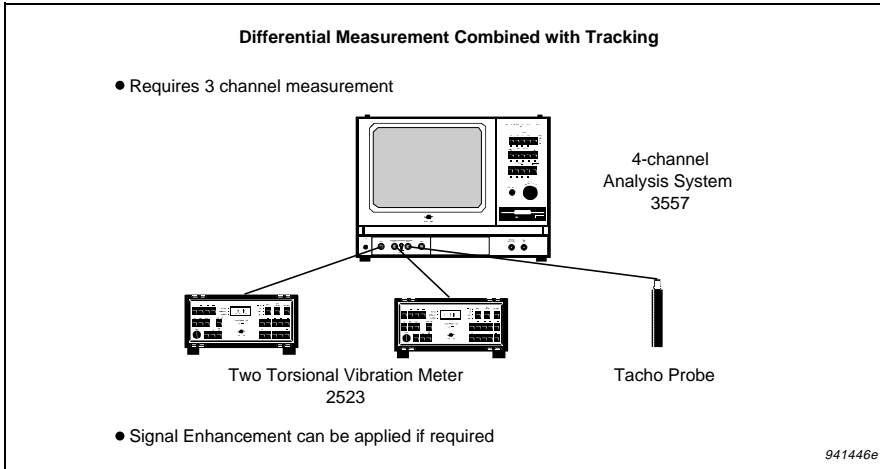

Fig. 8. User Definable Function (UDF) for differential measurements

Also employing a tacho probe, such as the MM0024 connected to the trigger input, the signal-to-noise ratio of the measurement was improved by e.g. 10 dB by applying synchronous time domain averaging (Signal Enhancement) of the two AC Signal Output time signals – before subtraction and subsequent frequency analysis. Note that Hanning Weighting is applied before the FFT is performed. As shown, such a real-time “twist” measurement with two Torsional Vibration Meters Type 2523 is easy and straightforward to perform.

The cursor reading indicates that the two measured sections of the shaft exhibit an angular vibration 178.8° out of phase, i.e. torsion. The amplitude read-out was in this case scaled to peak-to-peak velocity.

The use of three channels as shown in Fig.9 is required if differential measurements is combined with order tracking. This is due to the fact that the signal from the tacho probe must be applied to an input channel in order to calculate the



*Fig. 9. Setup used for differential measurement combined with both order tracking (and Signal Enhancement). The 4-channel Analysis System Type 3557 is used*

instantaneous RPM which is used for the variable sampling frequency. For synchronous time domain averaging the tacho probe is still used as a trigger.

## Conclusion

Advancing the analysis possibilities of traditional one-plane angular vibration measurements, the Torsional Vibration Meter Type 2523 can be used to measure the Torsional Operational Deflection Shape (TODS) of rotating shafts, rotating at a critical frequency. The instrumentation is based on the Multichannel Analysis System Type 3550, controlled by a Personal Computer running the Torsional Operational Deflection Shapes Software WT 9380\*.

Measuring the TODS of a rotating shaft means that torsional vibration problems can be investigated by viewing the deflection shape and thereby guide the vibration engineer in making optimal design modifications to control vibration and less wear and fatigue.

---

\* The WT9380 software has been developed by Vibration Engineering Consultants, Inc. Woburn, MA, USA.

## References

- [1] Døssing Ole, Brüel & Kjær: “*Structural Stroboscopy, – Measurement of Operational Deflection Shapes*”, Brüel & Kjær Application Note BO 0212
- [2] Licht R. Torben, Brüel & Kjær: “*A New Laser Based Method for Torsional Vibration Measurement*”. Copies available from Brüel & Kjær
- [3] Brüel & Kjær “*The Torsional Vibration Meter Type 2523*”. Product Data Sheet (BP 0958)
- [4] Schwibinger P., Hendrick D., Wu W. and Imanishi Y., Freudenberg-NOK.: “*Noise and Vibration Control Measures in the Powertrain of Passenger Cars*”. Proceedings of the 1991 SAE Noise & Vibration Conference, P-244/911053
- [5] Umeyama M., Kobayashi K., Hounoki S. and Otake T., Toyota Motor Corporation, Japan: “*The basic consideration of the two-mass flywheel with the torsional damper*”. Proceedings of the Institution of Mechanical Engineers (IMEchE 1990-10) c420/020
- [6] Honda Y. and Saito T, Waseda University, Department of Mechanical Engineering, Wakabayashi K. and Kodama T., Kokushikan University, Department of Mechanical Engineering, Iwamoto S., Saitama University, Department of Mechanical Engineering: “*A Simulation Method for Crankshaft Torsional Vibration by Considering Dynamic Characteristics of Rubber Dampers*”
- [7] Gatzwiller Kevin, Brüel & Kjær “*Measuring Torsional Operational Deflection Shapes of Rotating Shafts*”. Brüel & Kjær Application Note (BO0402)



# Previously issued numbers of Brüel & Kjær Technical Review

- 2 – 1996 Non-stationary Signal Analysis using Wavelet Transform, Short-time Fourier Transform and Wigner-Ville Distribution
- 1 – 1996 Calibration Uncertainties & Distortion of Microphones. Wide Band Intensity Probe. Accelerometer Mounted Resonance Test
- 2 – 1995 Order Tracking Analysis
- 1 – 1995 Use of Spatial Transformation of Sound Fields (STSF) Techniques in the Automotive Industry
- 2 – 1994 The use of Impulse Response Function for Modal Parameter Estimation Complex Modulus and Damping Measurements using Resonant and Non-resonant Methods (Damping Part II)
- 1 – 1994 Digital Filter Techniques vs. FFT Techniques for Damping Measurements (Damping Part I)
- 2 – 1990 Optical Filters and their Use with the Type 1302 & Type 1306 Photoacoustic Gas Monitors
- 1 – 1990 The Brüel & Kjær Photoacoustic Transducer System and its Physical Properties
- 2 – 1989 STSF — Practical instrumentation and application  
Digital Filter Analysis: Real-time and Non Real-time Performance
- 1 – 1989 STSF — A Unique Technique for scan based Near-Field Acoustic Holography without restrictions on coherence
- 2 – 1988 Quantifying Draught Risk
- 1 – 1988 Using Experimental Modal Analysis to Simulate Structural Dynamic Modifications  
Use of Operational Deflection Shapes for Noise Control of Discrete Tones
- 4 – 1987 Windows to FFT Analysis (Part II)  
Acoustic Calibrator for Intensity Measurement Systems
- 3 – 1987 Windows to FFT Analysis (Part I)
- 2 – 1987 Recent Developments in Accelerometer Design  
Trends in Accelerometer Calibration
- 1 – 1987 Vibration Monitoring of Machines
- 4 – 1986 Field Measurements of Sound Insulation with a Battery-Operated Intensity Analyzer  
Pressure Microphones for Intensity Measurements with Significantly Improved Phase Properties  
Measurement of Acoustical Distance between Intensity Probe Microphones  
Wind and Turbulence Noise of Turbulence Screen, Nose Cone and Sound Intensity Probe with Wind Screen
- 3 – 1986 A Method of Determining the Modal Frequencies of Structures with Coupled Modes

*(Continued on cover page 3)*

## Previously issued numbers of Brüel & Kjær Technical Review

*(Continued from cover page 2)*

- Improvement to Monoreference Modal Data by Adding an Oblique Degree of Freedom for the Reference
- 2 – 1986 Quality in Spectral Match of Photometric Transducers  
Guide to Lighting of Urban Areas
- 1 – 1986 Environmental Noise Measurements
- 4 – 1985 Validity of Intensity Measurements in Partially Diffuse Sound Field  
Influence of Tripods and Microphone Clips on the Frequency Response of Microphones
- 3 – 1985 The Modulation Transfer Function in Room Acoustics  
RASTI: A Tool for Evaluating Auditoria
- 2 – 1985 Heat Stress  
A New Thermal Anemometer Probe for Indoor Air Velocity Measurements
- 1 – 1985 Local Thermal Discomfort
- 4 – 1984 Methods for the Calculation of Contrast  
Proper Use of Weighting Functions for Impact Testing  
Computer Data Acquisition from Brüel & Kjær Digital Frequency Analyzers 2131/2134 Using their Memory as a Buffer
- 3 – 1984 The Hilbert Transform  
Microphone System for Extremely Low Sound Levels  
Averaging Times of Level Recorder 2317
- 2 – 1984 Dual Channel FFT Analysis (Part II)
- 1 – 1984 Dual Channel FFT Analysis (Part I)

## Special technical literature

Brüel & Kjær publishes a variety of technical literature which can be obtained from your local Brüel & Kjær representative.

The following literature is presently available:

- Modal Analysis of Large Structures – Multiple Exciter Systems (English)
- Acoustic Noise Measurements (English), 5th. Edition
- Noise Control (English, French)
- Frequency Analysis (English), 3rd. Edition
- Catalogues (several languages)
- Product Data Sheets (English, German, French, Russian)

Furthermore, back copies of the Technical Review can be supplied as shown in the list above. Older issues may be obtained provided they are still in stock.

HEADQUARTERS: DK-2850 Nærum · Denmark  
Telephone: +45 45 80 05 00 · Fax: +45 45 80 14 05  
Internet: <http://www.bk.dk> · e-mail: [info@bk.dk](mailto:info@bk.dk)

**Brüel & Kjær** 